

# Indoor Direct View GOB LED Solutions

P1.8



*A bespoke all-in-one solution for creating seamless, high-performance displays that enhance and transform any indoor environment*

## Unmatched Durability

GOB (Glue on Board) LED displays feature a protective resin coating for superior durability. With excellent impact resistance, they safeguard LEDs from damage during installation and in high-traffic environments.

The sealed design also blocks dust and moisture, ensuring reliable, low-maintenance performance in demanding public spaces.

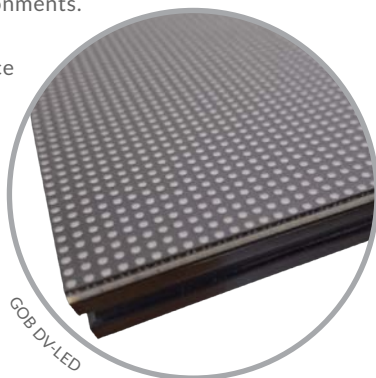
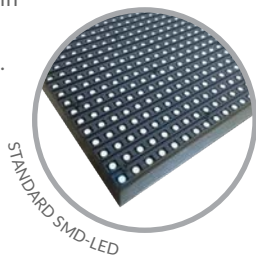

## Enhanced Image Quality

By combining state-of-the-art SMD technology with advanced video processing, GOB displays deliver crystal-clear visuals and vibrant, lifelike colours. The transparent resin layer does not affect the brightness, colour, or sharpness of the image. It also enhances surface uniformity for deeper black levels, better contrast, and consistent brightness, while high refresh rates guarantee seamless content playback.



Seamless Video Walls



Enhanced Protective Finish



Easy Install & Maintenance



Ultra High Contrast Ratio



800cd/m<sup>2</sup> Brightness



Ultra-Quiet Operation



End-to-End Project Management



Comprehensive Quality Control



UK Stock Held

## Other Features

### Complete Packaged Solution

This all-in-one package contains everything needed to get your display up and running, including the LED modules and mounting bracket. For larger DV-LED video walls an aluminium screen edge can also be made to order at no additional cost, protecting the display and improving the overall aesthetic.

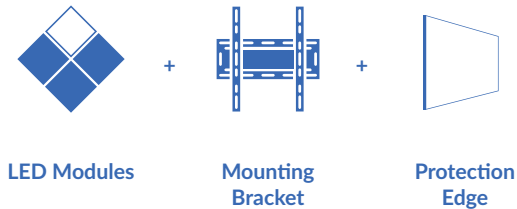

### Long-Lasting Performance

GOB DV-LED displays are built for longevity, with a protective resin layer that ensures even heat dissipation, reducing the risk of burnout and extending the display's lifespan. Fully encapsulated LEDs offer enhanced protection against impact, minimising failures and ensuring reliable performance in demanding environments.

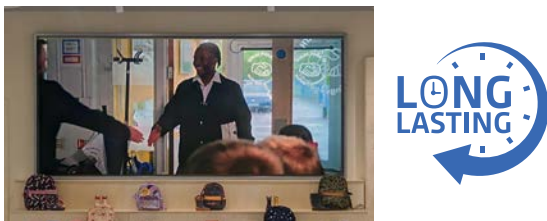

### UK Stock Held

Our fully-stocked UK warehouse means we can fulfil projects with a rapid turnaround time if required. From initial enquiry to finished installation, by holding extensive stock in the UK we can deliver results without long delays.



### Comprehensive Quality Control

From production through to installation, our DV-LED solutions undergo multiple rounds of strict quality control to ensure long-lasting reliability. In addition, quality calibration guarantees consistent image quality across the whole display.



### Easy Installation & Maintenance

With a lightweight design, magnetic modules, and positioning pins, GOB displays are quick and easy to install. The durable aluminum cabinets ensure perfect alignment, while front-access servicing allows fast module replacement. The smooth resin surface makes cleaning simple by preventing dirt buildup, and the protected LEDs minimize the risk of damage during handling, reducing maintenance costs.



### Bespoke Video Walls

Thanks to their modular design, these versatile displays are not constrained by standard aspect ratios. Stand out from the crowd by sculpting seamless large-scale video walls to fill spaces of any shape and size in any location. The unique cabinet size gives ultimate flexibility by ensuring a 16:9 aspect ratio is also possible.

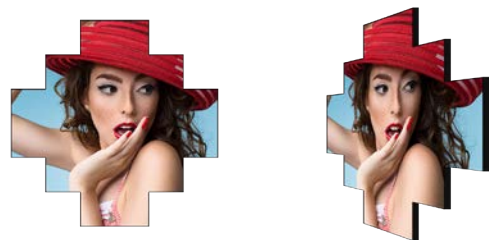

### Remote Content Updates

Publish and monitor content from anywhere in the world via the internet using our own cloud-based CMS software, which is designed to be cost-effective and user-friendly. Plus, avoid the hassle associated with coordinating multiple suppliers by sourcing hardware and software from one place.

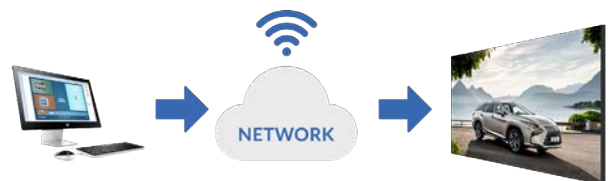

### End-to-End Project Management

Every DV-LED project is unique and they each come with their own challenges, but we're here to advise and support you every step of the way. From designing bespoke displays to ensuring hassle-free installation and even providing maintenance, we can deliver full end-to-end project management where required.

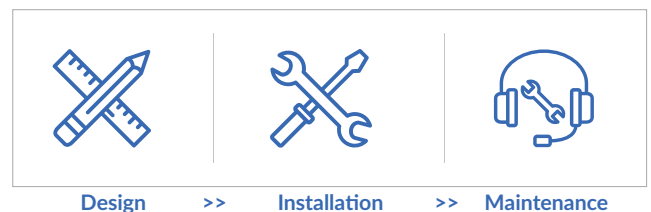

# Key Features



OPTIMISED FOR INDOORS



ENHANCED IMAGE QUALITY



ULTRA HIGH CONTRAST RATIO



FLAT SCREEN SURFACE



SEAMLESS VIDEO WALLS



800CD/M<sup>2</sup> BRIGHTNESS



SLIM LIGHTWEIGHT CABINETS



MODULAR DESIGN



GLUE-ON-BOARD  
PROTECTIVE FINISH



FRONT  
SERVICEABILITY

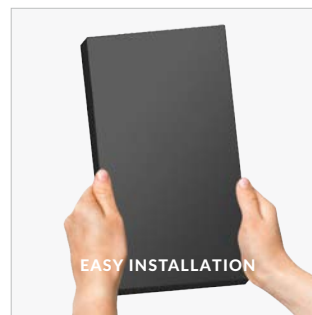

EASY INSTALLATION

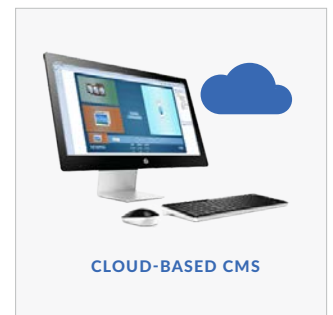

CLOUD-BASED CMS

## Specification Table

		P1.8
LED Display	Pixel Pitch (mm)	1.839
	LED Type	SMD1515
	Pixel Configuration	1R1G1B
	Brightness (Calibrated)	800cd/m <sup>2</sup>
	Refresh Rate	2880Hz
	Contrast Ratio	6,500:1
	Viewing Angle - Horizontal	170°
	Viewing Angle - Vertical	170°
	Processing	12 bit
	Frame Rate	60 fps
	Maintenance	Front service
Cabinet	Module Resolution (px)	174x87
	Module Size (mm)	320x160x14.5
	Cabinet Resolution (px)	348x261
	Cabinet Size (with Modules) (mm)	640x480x32±1
	Net Weight (Kg)	6.2
Power	Input Voltage	240V AC
	Cabinet Current	<0.45A
	Average Power Consumption (Per Cabinet)	36W
	Max Power Consumption (Per Cabinet)	110W
	Standby Power Consumption (Per Cabinet)	0.5W
Environmental	IP Rating	TBC
	Operating Temperature	-10°C to +30°C
	Storage Temperature	-20°C to +40°C
	Operating Humidity	10% to 65%
	Storage Humidity	10% to 60%
	Lifetime	100,000 hours
Warranty	Warranty Period	3 Year Warranty
	Technical Support	Lifetime

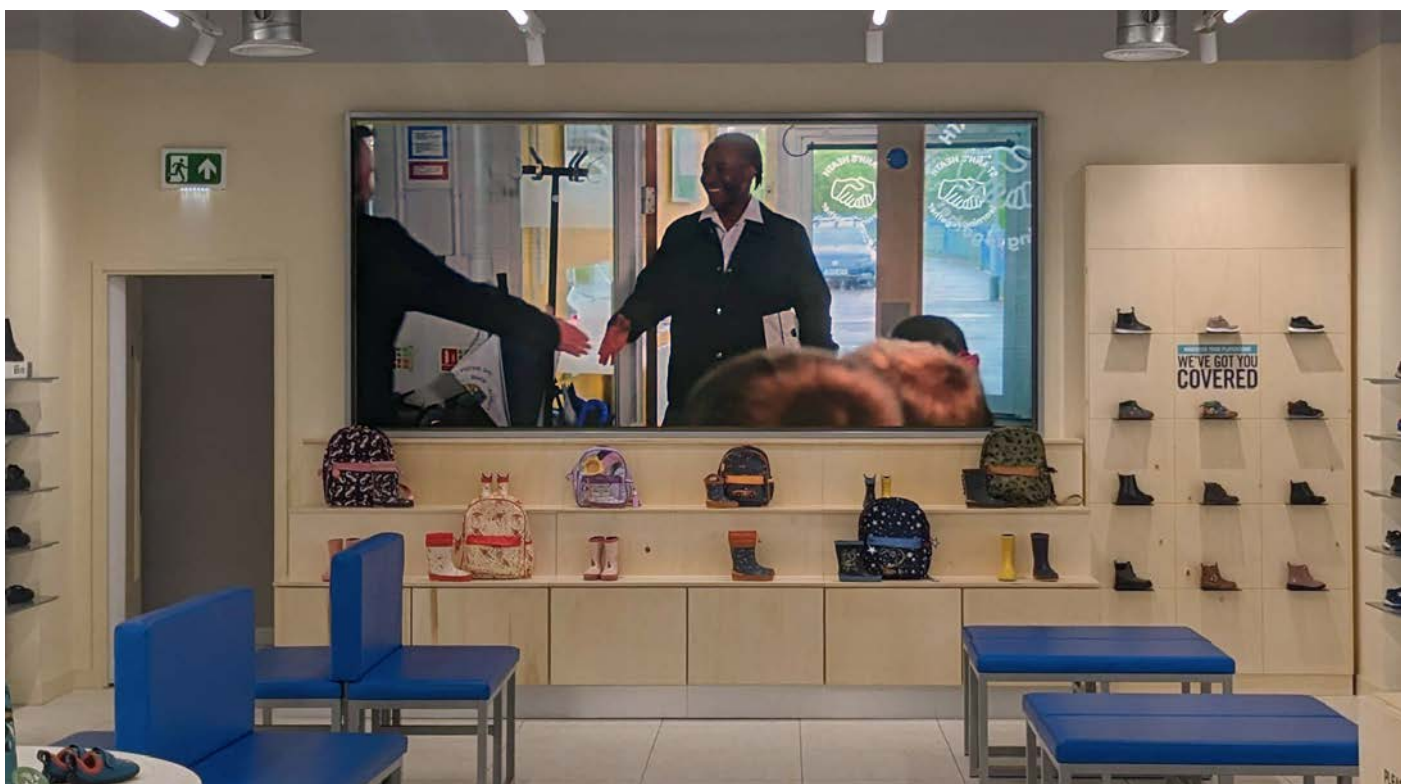

# Cabinet Technical Drawing

---

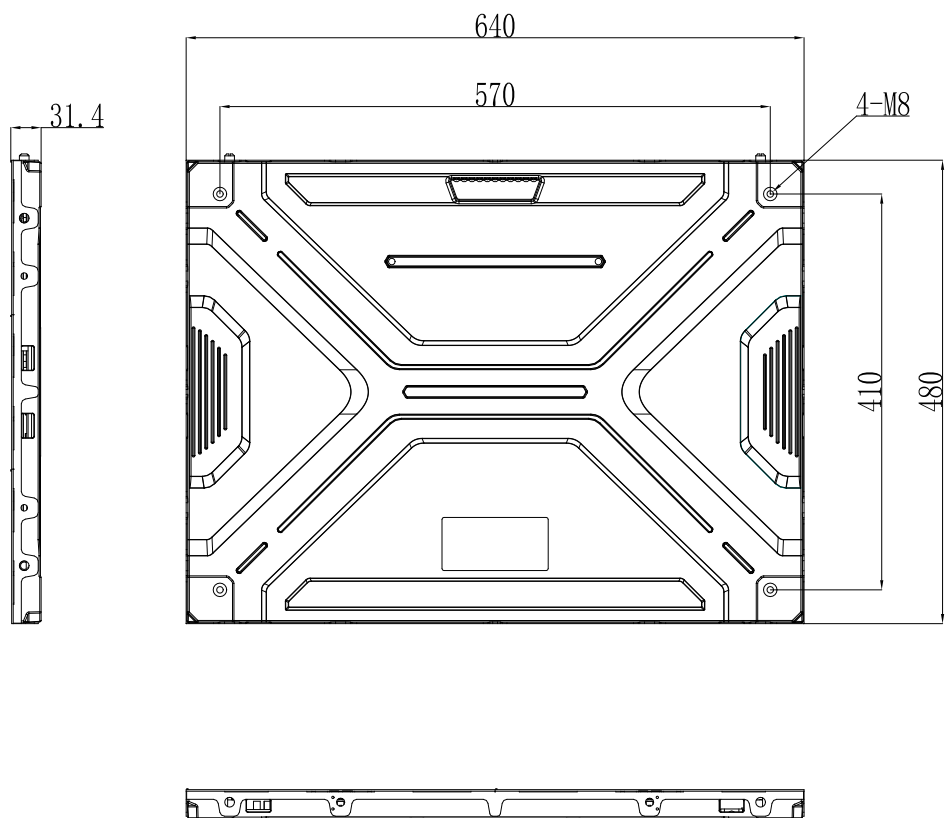

# Why Choose Our Commercial Display Solutions?



## Lifetime Technical Support

From the moment you receive your product, throughout the duration of your warranty and even after your warranty has expired we are here to support you. If you require any assistance setting up or using your product, or have any problems at all, we can provide free technical support via telephone and email.

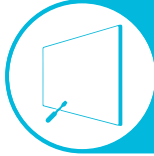

## On-site Support and Maintenance\*

If needed, we can provide an installation service for any of our products. We can also set up service-level agreements for larger projects that require maintenance contracts.



## Extended Warranty\*

All of our commercial display products come with a 3 year commercial warranty as standard but if you want to extend this you can upgrade this to cover a 5 year period at point of purchase.



## Training

As well as providing free remote CMS training sessions and webinars we can also visit you to deliver bespoke training for our software and hardware\*.



## Advanced Replacements†

Should your display suffer from any kind of hardware failure during the warranty period we will send you an advanced replacement and arrange for your old display to be collected, free of charge. This ensures no downtime where you are without a screen.



## Custom Product Testing & Configuration

If you need us to test third party software or a website, or configure your screen in a particular way before it is dispatched (e.g. in a particular orientation or network mode), we can do so to make your life easier.



## 3D Rendering

Want to know how a particular screen will look once installed? Send us a photo of the location and we will create a 3D rendering of any screen in situ to help you to visualise how amazing it will look.



## Logistics Support

We hold more stock in our UK warehouse than any other manufacturer so we can help you meet tight deadlines. For last minute orders we can also offer special express or morning delivery options\*. We also carry out UK based quality control checks on every display before it leaves our warehouse.



## Project Support

If you need to loan a sample unit to test we'd be more than happy to arrange this. We can also provide a rental service for temporary projects\*.



## Customisation\*

Your display can be customised to suit your requirements by adding your logo or printed graphics or even tailoring the colour of a display. We can also carry out hardware modifications to existing products or manufacture bespoke solutions for special projects.



## Extras\*

As well as being able to provide accessories and add-ons, such as extra remote controls, NUC PCs and video wall controllers, we can also supply custom made flight cases which are great if a display needs to be moved safely from place to place.

†UK mainland only

\*These particular services may incur additional charges